



Brave 1 LM 740
code .142



Brave 2 LM 740
code .242



Brave 2 LM 740
code .262

SIMBOLOGIA / SIMBOLOGY pag. 8-9



COLORI DISPONIBILI / AVAILABLE COLOURS

2 COLORE STANDARD
STANDARD COLOUR

Nero
Black

OPZIONI DI INSTALLAZIONE / INSTALLATION OPTIONS



VERSIONI DISPONIBILI / AVAILABLE VERSIONS

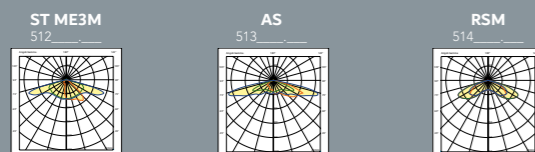

DIMENSIONI / DIMENSIONS

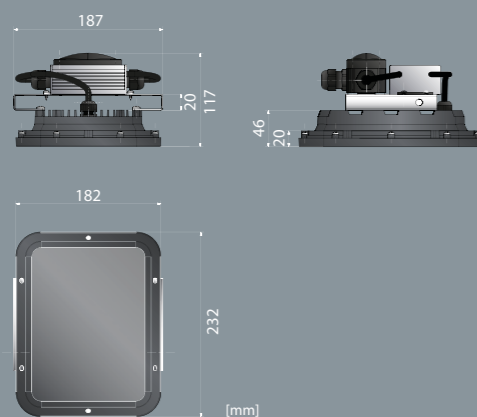

DIMENSIONI IMBALLO / PACKING DIMENSIONS

m³ 0,016
420x290x135mm
1 Pcs
100 pcs

TEMPERATURA COLORE DISPONIBILE / COLOUR TEMPERATURE AVAILABLE pag. 136

CCT 4000K COLORE STANDARD
STANDARD COLOUR



DISPONIBILE A RICHIESTA / AVAILABLE ON REQUEST

- driver DALI;
- CRI80,*
- lenti ambra;
- SPD 10kV;
- kit staffa di rotazione.
- DALI driver;
- CRI80,*
- amber lenses;
- SPD 10kV;
- rotating bracket kit.

DETTAGLI / DETAILS

Brave

retrofit universale per
arredi urbani
universal retrofit for
decorative street fixtures

Piastra di supporto
non inclusa*
Support plate
not included*

Brave
retro / back

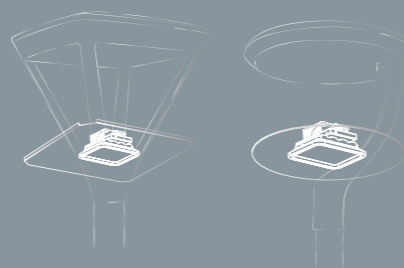

Proiettore multiottica di bassa potenza in classe II, sviluppato come perfetto **retrofit** per lanterne, apparecchi decorativi per arredo urbano, piccole armature stradali.

Corpo e cornice: resina termoconduttiva, in colore nero.
Vetro di sicurezza: extra chiaro temprato da 4 mm.
Moduli LED: anti solforazione, CRI>70, CCT 4000K, SDCM 5.
Mantenimento del flusso luminoso: 54.000h L80 B10 @ta25, 54.000h L80 B10 @ta45.
Lente: cluster multiplo 2x2 in PMMA Anti UV UL94.
Ottiche: stradale ME3M, AS e RSM.
Alimentazione: elettronica 220 ÷ 240V 50-60Hz, protezione alla scarica 4/6kV, low ripple.
Installazione: apparecchio retrofit.

Low power class II multi-optical projector, developed as a perfect **retrofit** for lanterns, decorative luminaires, urban furniture, street lighting.

House and frame: thermoconductive resin, color black.
Safety glass: extra clear tempered 4 mm.
LED modules: anti sulfuration, CRI>70, CCT 4000K, SDCM 5.
Lumen maintenance: 54.000h L80 B10 @ta25, 54.000h L80 B10 @ta45.
Lens: 2x2 multiple cluster in PMMA Anti UV UL94.
Optics: ME3M street light distribution, AS and RSM.
Power supply: 220 ÷ 240V 50-60Hz with electronic ballast, surge protection 4/6kV, low ripple.
Installation: retrofit fixture.

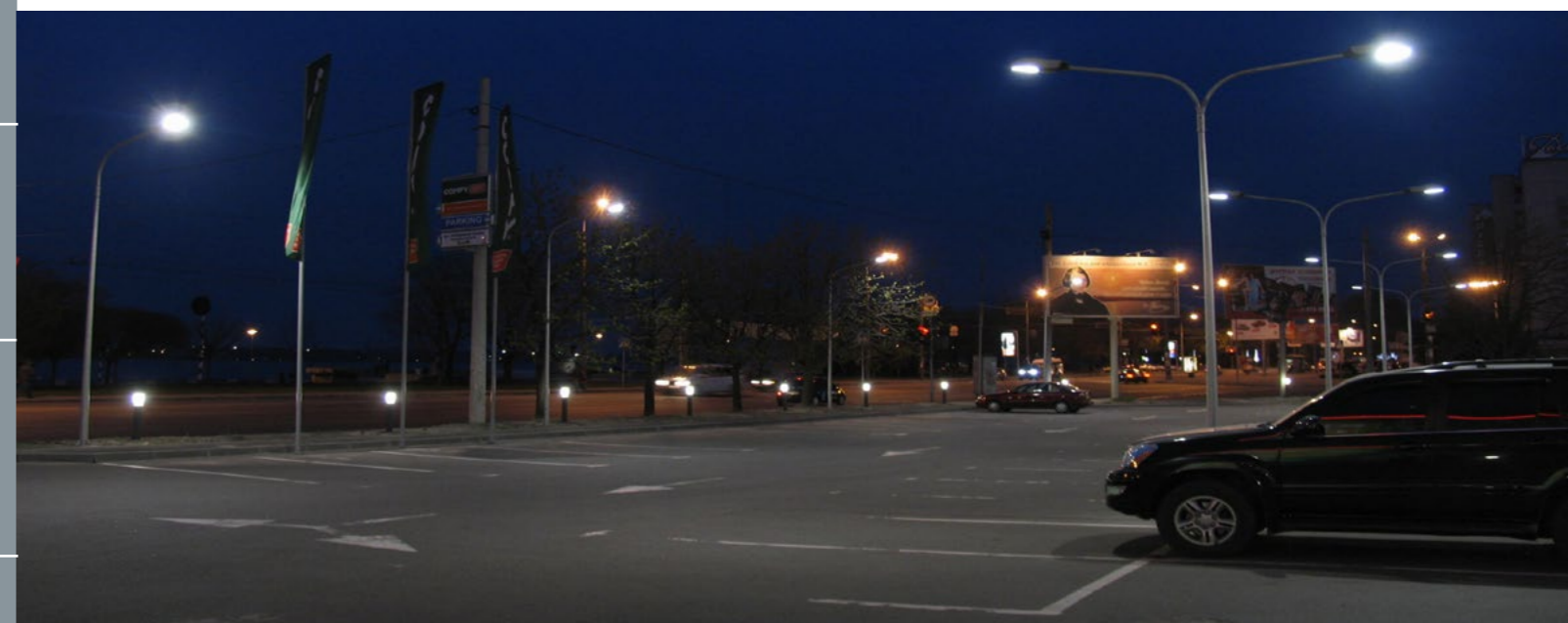

	CODICE Code	DESCRIZIONE Description	POTENZA Power(W)	FLUSSO NOMINALE Typical flux(lm)	FLUSSO NETTO Net output(lm)	CORRENTE Current(mA)	SPD Spd(kV)	PESO NETTO Net weight(Kg)
ST ME3M	512642.142	1 LM 740	16W	2850	2385	700	4/6	1,85
	512642.242	2 LM 740	32W	5700	4770	700	4/6	1,88
	512642.262	2 LM 740	48W	8550	7150	700	4/6	1,94
AS	513642.142	1 LM 740	16W	2850	2110	700	4/6	1,85
	513642.242	2 LM 740	32W	5700	4220	700	4/6	1,88
	513642.262	2 LM 740	48W	8550	6330	700	4/6	1,94
RSM	514642.142	1 LM 740	16W	2850	2475	700	4/6	1,85
	514642.242	2 LM 740	32W	5700	4950	700	4/6	1,88
	514642.262	2 LM 740	48W	8550	7425	700	4/6	1,94
	code + DALI	Driver dimmerabile DALI DALI dimmable driver						
	951203.000	Kit staffa di rotazione Rotating bracket kit						

ATTENZIONE: Piastra di supporto custom a richiesta, progettata su campione fornito dal cliente*
ATTENTION: Custom support plate on request, designed based on a sample provided by the customer*